



hermanos
garcía
REMOLQUES

REMOLQUES SERIE LIGERA LIGHT RANGE



1 axle

EL

P-45N

BAÑERA
Bin-type
trailer



I-P8

MODULARES
Modular
trailers



I-P7

BAÑERA
Bin-type
trailer



P-3N

**BAÑERA
INOXIDABLE**
Stainless
steel
bin-type
trailer



I-PIO

BAÑERA
Bin-type
trailer



Cierre tres posiciones
3 positions lock



Bisagras desmontables y pilar de cuña
Removable hinge and pillar



Cierre de Barra
Tir lock



Suspensión Ballesta
Spring suspension



Apoyo Fijo
Fixed foot



Apertura Automática
Automatic opening



Uña de Cierre
Security closing system

Goma y Carril
Rubber and slide



2 axles

PT-7

BAÑERA

Bin - type trailer



PT-7

MODULARES

Modular trailers

MODELO	MODEL	P-3N	P-45N
Nº DE EJES	Nº OF AXLES	1	1
DIMENSIONES EJE Y TAMBOR	DIMENSIONS OF AXLES AND DRUMS	60# 250 X 40	60# 250 X 40
MODULARES	MODULAR TRAILERS		
CAPACIDAD (M3)	CAPACITY (M3)	3,6	4,9
MODELO DE NEUMÁTICOS	MODEL OF TYRES	10,75 - 15,3	11,5 - 15,3 / 14
TIPO DE NEUMÁTICOS	TYPE OF TYRES	NUEVO NEW	NUEVO NEW
DIMENSIONES EXTERIORES	EXTERIOR DIMENSIONS	325 - 195	325 - 195
ALTURA DE CAJA	BOX HEIGHT	65 + 25	65 + 25
ANCHURA INTERIOR	INTERIOR WEIGHT	176	176
BAÑERAS	BIN - TYPE TRAILERS		
CAPACIDAD	CAPACITY	3,7	5,1
MODELO DE NEUMÁTICOS	MODEL OF TYRES	10,75 - 15,3	11,5 - 15,3 / 14
TIPO DE NEUMÁTICOS	TYPE OF TYRES	NUEVO NEW	NUEVO NEW
DIMENSIONES EXTERIORES	EXTERIOR DIMENSIONS	330 - 194	330 - 194
ALTURA DE CAJA	BOX HEIGHT	65	65 + 25
APERTURA TRASERA	BACK DOOR	MANUAL MANUAL	MANUAL MANUAL

SEER

P-8

BAÑERA

Bin - type trailer



P-8

MODULARES

Modular trailers



I-P7	I-P8	I-PIO	PT-7 / P-7C	PT-8 / P-8
1	1	1	2	2
70# 300 X 60	70# 300 X 60	80# 300 X 60 90# 350 X 60	70# 300 X 60 FRENO 1 EJE brake 1 axle	70# 300 X 60 FRENO 2 EJES brake 2 axles
5,1	8	10,7	8	10,7
11,5 - 15,3 / 16	285/70R19,5	285/70R19,5	11,5 - 15,3 / 14	11,5 - 15,3 / 16
NUEVO NEW	NUEVO NEW RADIAL RADIAL	RADIAL RADIAL NUEVO NEW	NUEVO NEW	NUEVO NEW
390 - 208	390 - 208	435 - 218	390 - 208	435 - 218
70	70 + 40	75 + 50	70 + 40	75 + 50
192	192	202	192	202
6	8,2	10,2	8,2	10,2
11,5 - 15,3 / 16	285/70R19,5	385/65R22,5	11,5 - 15,3 / 14	11,5 - 15,3 / 16
NUEVO NEW	NUEVO - RADIAL NEW / RADIAL	RENOVADO RETREAD	NUEVO NEW	NUEVO NEW
395 - 212	395 - 212	460/440 - 222	395 - 212	460/440 - 222
80	110 Ó 80 + 30	130	110 Ó 80 + 30	130
AUTOMÁTICA AUTOMATIC	AUTOMÁTICA AUTOMATIC	AUTOMÁTICA AUTOMATIC	AUTOMÁTICA AUTOMATIC	AUTOMÁTICA AUTOMATIC

Detalles

Details

Planos Boggie Boggie plans



Giratorio Modular
Modular revolving axles



Grifo
Tap

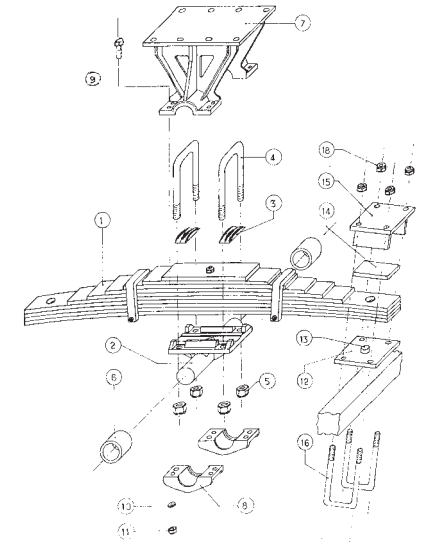
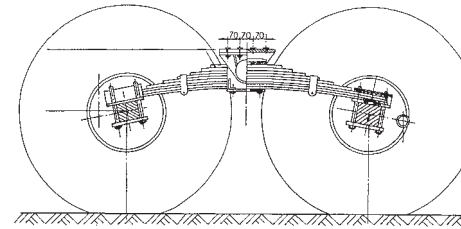

Salas de fábrica
Factory's rooms

Sala robotizada
Robotized room



Sala de granalla
Metallic grit blast's room



Sala de pintura
Painting room



RUEDAS Tyres



10,75 - 15,3
11,5 - 15,3



7,5 - 16
8,25 - 15



400/60 - 15,5
Reinforcer Reinforced



285/70 - 19,5
Diagonal diagonal



285/70R19,5
Radial Radial



385/65R22,5
Radial Radial



435/50R19,5
Radial Radial

EQUIPAMIENTO

EQUIPMENT

EQUIPAMIENTO DE SERIE

Apertura automática en bañeras (excepto P-3N y P-45N).
Apoyo manual extraíble (excepto P-3N y P-45N).
Ballestas de amortiguación todos modelos 2 ejes y I-PIO (I eje).
Basculantes con cilindro de elevación central.
Caja cónica en bañeras modelos PT-8 y P-8.
Caja plegada en bañeras, resto de modelos.
Chasis inferior y superior estructural tubo.
Cierre de barra tipo TIR en modulares desde I-P8.
Cierre de manilla en modulares modelos P-3N, P-45N y I-P7.
Lanza regulable en altura.
Pintura al horno previo granallado.
Puerta 2 posiciones en modulares.
Soporte de giratorio modular modelos P-7C y P-8.
Suspensión de ballestas BOGGIE modelos PT-7 y PT-8.
Trampilla trasera desde modelos I-P8.

STANDARD EQUIPMENT

Automatic door on bin-type trailers (except on P3n and P45n models);
Extractable manual foot (except on P3n and P45n models);
Spring suspension on all the models with 2 axles and IPIO (I axle);
Dumpers with central cylinders;
Conical box on bin-type trailers (PT-8 and P-8 models);
Folded box on bin-type trailers (rest of the models);
Structural tube upper and lower chassis;
Lock system with central bars on modular trailers (from I-P8);
Handle lock system on modular trailers on P3n, P45 and IP7 models;
Adjustable sprung drawbar;
Oven baked finish paint applied after metallic grit blasting;
2 positions door on modular trailers (p3n, P45n and IP7);
Modular support for revolving axle on models P75 and P8;
Boggie sprung drawbar on models PT7 and PT8;
Trap door from IP8 model.

ACCESORIOS OPCIONALES

Apertura hidráulica en bañeras modelos PT-8 y P-8.
Apoyo hidráulico con bomba manual.
Apoyos traseros manuales modelos PT-7 y PT-8.
Ballestas de amortiguación en modelos de I eje (excepto I-PIO).
Cajón de herramientas y depósito de agua.
Carril y goma para líquidos.
Ejes curvos modelos P-7C y P-8.
Frenos de aire ó mixtos.
Ganchos de atar
Grifo ó llave de 3" en bañeras.
Neumáticos diferentes modelos y tipos.
Pintura E-poxi alimentario en bañeras.
Puerta trasera 3 posiciones en modulares.
Trampilla trasera modelos P-3N, P-45N y I-P7.

OPTIONAL EQUIPMENT

Hydraulic door on bin-type trailers on models PT8 and P8.
Hydraulic foot with manual pump.
Back manual feet on models PT7 and PT8.
Arches and different type of canvas.
Sprung drawbars for models with I axle.
Tool box and water deposit.
Slide and rubber for liquids (on bin-type trailers).
Curved axles on models P75 and P8.
Air brakes or mixed brakes.
Hooks for tying.
Tap or valve 3 inches on bin-type trailers.
E-POXI alimentary paint inside on bin-type trailers.
3 positions back door on modular trailers.
Trap door on models P3n, P45n and IP7.



LÍDERES EN CALIDAD LEADERS IN QUALITY



Ctra. Cogeces del Monte, Km 0,5
47300 Peñafiel - Valladolid (ESPAÑA)
Telf: +34 983 880 011 · Fax: +34 983 881 465
r@remolqueshnosgarcia.com
www.remolqueshnosgarcia.com

DISTRIBUIDOR DEALER

